

ZONE		REV	DESCRIPTION	CN	DATE	PREP	APVD
D6	A1		UPDATE LOCATION E	80071517	2015/05/11	P216383	P00840

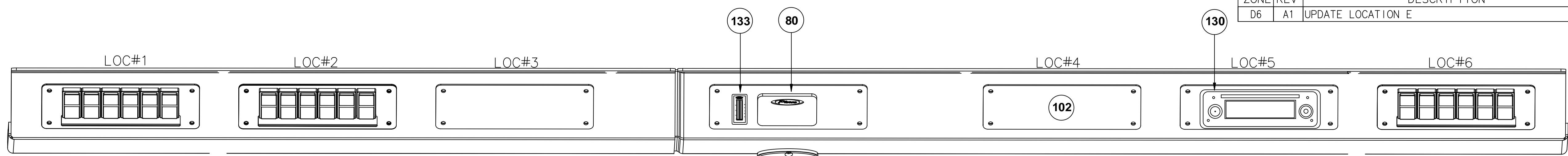

REFERENCE	APPROX. DIMENSIONS
LOC#1-6, #9-11	3.0" X 8.0"
LOC#7 & 8	8.1" X 7.4"
PNL POS A	8.31" X 5.90"
PNL POS B	24.65" X 6.63"
PNL POS C	25.18" X 21.08"
PNL POS D	5.00" X 30.38"
PNL POS E	8.1" X 7.4"

DO NOT MOVE TRUCK LIGHT

ANGLE MONITOR 45 DEGREES @ DS END OF PLATE MOUNTED AS LOW AS POSSIBLE (TABS OFF BOTTOM OF PLATE)

DRIVER'S SIDE

NOTE: 1-10, 16-20, 29-33 ARE PART OF A NON MODIFIABLE GAUGE ASSEMBLY.

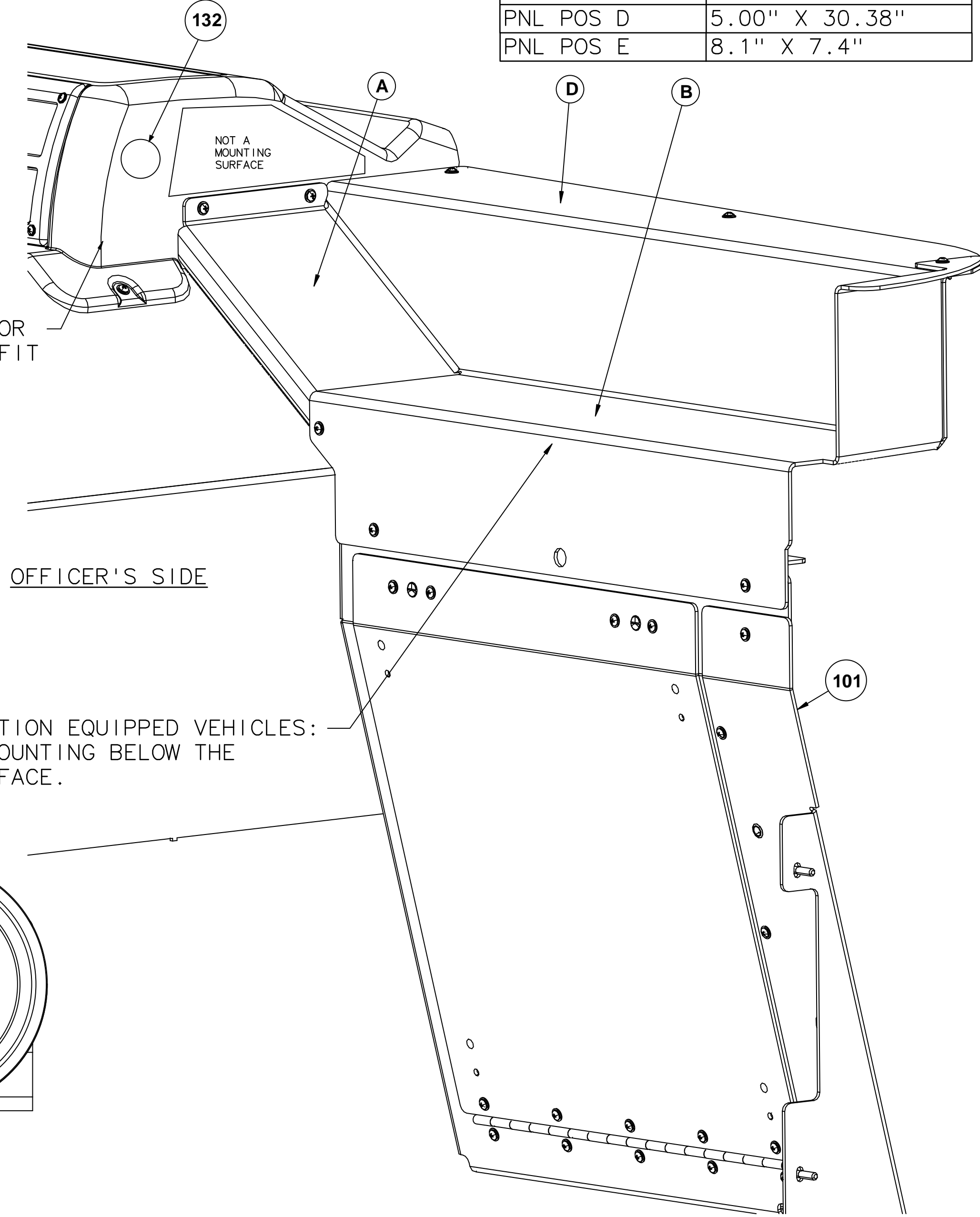
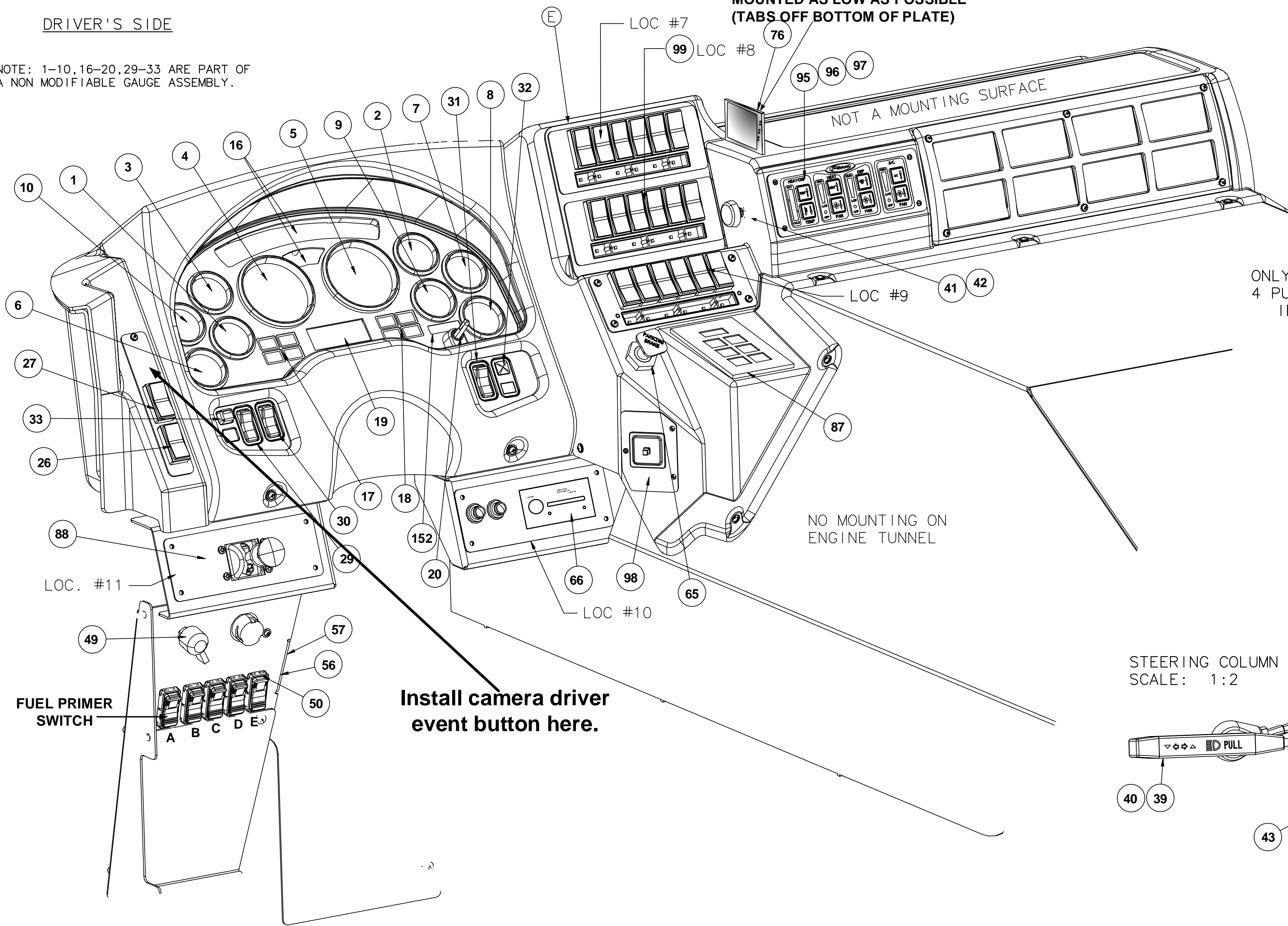

ONLY 3 POWERPOINTS OR 4 PUSHBUTTONS WILL FIT IN THIS LOCATION.

FRONTAL PROTECTION EQUIPPED VEHICLES: NO COMPONENT MOUNTING BELOW THE HORIZONTAL SURFACE.

NO MOUNTING ON ENGINE TUNNEL

Install camera driver event button here.

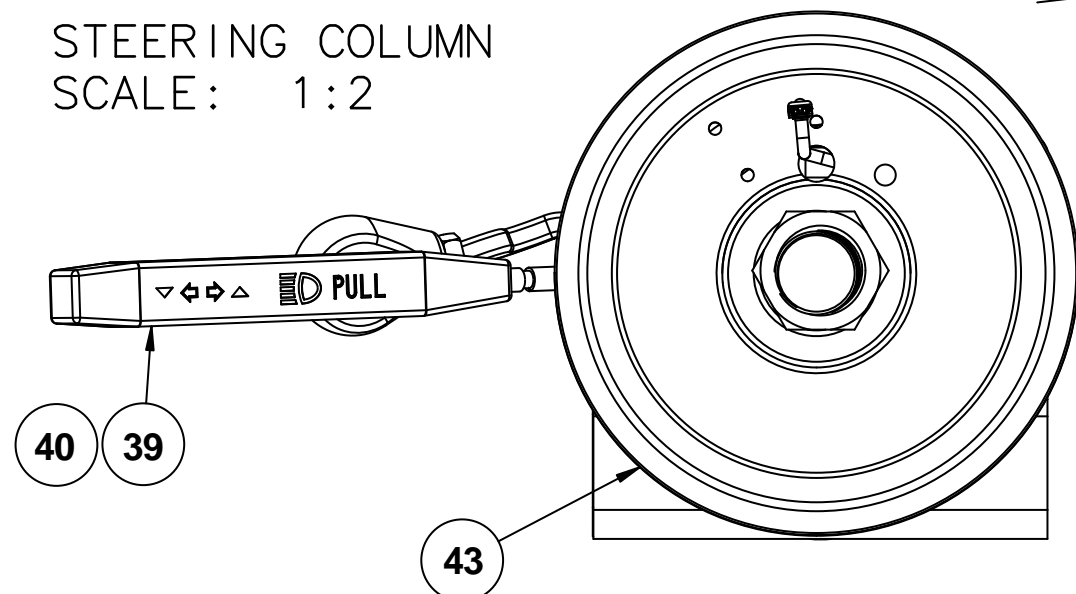

- NOTES:**
1. REFERENCE SHEET 66-0240SH2 FOR COMPONENT LIST.
 2. REFERENCE SHEET 66-0240SH3 FOR INDIVIDUAL SWITCH ASSIGNMENTS.
 3. SYMBOLS ARE FOR LOCATION REFERENCE ONLY. ACTUAL COMPONENT APPEARANCE MAY VARY.
 4. ONLY COMPONENTS REPRESENTED BY SOLID BUBBLES WILL BE PROVIDED AS STANDARD.

COMMERCIAL (EAR99)

THIS DRAWING IS SUBJECT TO THE EXPORT ADMINISTRATION REGULATIONS. YOU MAY NOT PROVIDE IT TO ANY PROHIBITED END-USERS OR FOR ANY PROHIBITED END-USES AS SET FORTH IN U.S. EXPORT CONTROLS.

THIS DRAWING IS PROVIDED ON A CONFIDENTIAL BASIS SUBJECT TO RETURN ON DEMAND BY PIERCE MANUFACTURING INC. ("PIERCE"), WHICH RETAINS ANY AND ALL RIGHTS ASSOCIATED WITH IT AND THE ARTICLE OR ARTICLES IT REPRESENTS. DISCLOSURE, REPRODUCTION OR ALTERATION OF ANY PART OF THIS DRAWING, OR MANUFACTURE, USE OR SALE OF THE ARTICLE OR ARTICLES REPRESENTED, IS PROHIBITED WITHOUT THE PRIOR WRITTEN AUTHORIZATION OF PIERCE. ©PIERCE MANUFACTURING INC. (unpublished).

JOB #: 33606 SPECIAL LAYOUT BY: DVA DATE: 05/15/19

REFERENCE: STA	APPROVALS	USER ID	DATE
ALL DIMENSIONS IN INCHES UNLESS OTHERWISE NOTED		P03609	2014/01/08
TOLERANCE UNLESS NOTED	APPROVED	P213372	2014/01/08
2 PLACES ±0.06	MFG ENG		
3 PLACES ±0.015	CN		CATIA V5R21
ANGULAR ±1.0°	MIN: N/A		
CONTRACT NO.	FINISH: RAW		
MATERIAL: SEE DETAILS	SIZE: D	CAGE NO. 04664	DWG NO. 66-0240SH1
	SCALE: 1:6	WEIGHT	REV
			01 OF 01

PIERCE MANUFACTURING APPLETON, WI 54912 USA
LAYOUT, INST PNL, SABER

Item #	Device Name	IND COLOR	STD	OPTIONAL
1	ENGINE OIL PSI GAUGE		X	
	LOW ENGINE OIL PSI IND	RED	X	
2	VOLTMETER		X	
	LOW/HIGH VOLTAGE IND	AMBER	X	
3	ENGINE COOLANT TEMP GAUGE		X	
	HIGH ENGINE COOLANT TEMP IND	RED	X	
4	TACHOMETER		X	
5	SPEEDOMETER		X	
6	TRANS OIL TEMP GAUGE		X	
	HIGH TRANS OIL TEMP IND	AMBER	X	
7	FRONT AIR PSI GAUGE		X	
	LOW FRONT AIR PSI IND	RED	X	
8	REAR AIR PSI GAUGE		X	
	LOW REAR AIR PSI IND	RED	X	
9	FUEL GAUGE		X	
	LOW FUEL LEVEL IND	AMBER	X	
10	DIESEL EXHAUST FLUID LEVEL GAUGE		X	
	LOW DIESEL EXHAUST FLUID LEVEL IND	AMBER	X	
11				
12				
13				
14				
15				
16	MULTIPLEX INDICATOR LIGHTS		X	
	LEFT DIRECTIONAL	GREEN	X	
	RIGHT DIRECTIONAL	GREEN	X	
	HIGH BEAM INDICATOR	BLUE	X	
	LOW COOLANT	AMBER	X	
	CHECK ENGINE	AMBER	X	
	AUX BRAKE OVERHEAT	AMBER	X	
	CAUTION	AMBER	X	
	WARNING	RED	X	
	PARK BRAKE APPLIED	RED	X	
	STOP ENGINE	RED	X	
	DPF REGENERATION	AMBER	X	
	ABS TRAILER FAULT	AMBER	X	
	GRID HEATER - WAIT TO START	AMBER	X	
	TRACTION CONTROL	AMBER	X	
	CHECK TRANSMISSION	AMBER	X	
	AIR RESTRICTION	AMBER	X	
	WATER IN FUEL	AMBER	X	
	FASTEN SEATBELTS	RED	X	
	RACK DOWN	RED	X	
	ENGINE HIGH EXHAUST TEMP	AMBER	X	
	ABS TRACTOR FAULT	AMBER	X	
	EMISSION SYSTEM MALFUNCTION	AMBER	X	
17	LEFT HARDWIRED INDICATOR LIGHT BANK		X	
	SIDE ROLL FAULT	AMBER	X	
	FRONTAL AIR BAG FAULT	AMBER	X	
	BATTERY SYSTEM ON	GREEN	X	
	SRS FAULT	AMBER	X	
18	RIGHT HARDWIRED INDICATOR LIGHT BANK		X	
	DPF REGENERATION (CUMMINS)	AMBER	X	
	LOW DIESEL EXHAUST FLUD LEVEL	AMBER	X	
	GRID HEATER - WAIT TO START (CUMMINS)	AMBER	X	
	EMISSION SYSTEM MALFUNCTION	AMBER	X	
19	LCD DISPLAY ON GAUGE ASSEMBLY		X	
	ODOMETER - MILES/KM		X	
	TRIP ODOMETER - MILES/KM		X	
	OUTSIDE AIR TEMP - F/C		X	
	PTO A HOURS		X	
	PTO B HOURS			
	ENGINE HOURS			
20	LCD MULTI-FUNCTION CONTROL			
21				
22				
23				
24				
25				
26	IGNITION / ALARM SILENCE SWITCH AND IGN IND	GREEN	X	
27	START SWITCH		X	
28				
29	HEADLIGHT/PARKLIGHT SWITCH		X	
30	DIMMER CONTROL		X	
31	HIGH IDLE SWITCH/IND	GREEN	X	
32	OK HIGH IDLE IND	GREEN	X	
33	EMERGENCY MASTER E-M BUTTON/IND	GREEN	X	
34				

NOTES:
1) ITEMS MARKED WITH AN "X" WILL BE PROVIDED. ITEMS NOT MARKED WILL NOT BE PROVIDED.
2) REFERENCE INSTRUMENT PANEL LAYOUT 66-0240SH1

Item #	Device Name	IND COLOR	STD	OPTIONAL
35				
36				
37				
38				
39	DIRECTIONAL SWITCH		X	
40	HEADLIGHT HI/LOW BEAM SWITCH		X	
41	WIPER CONTROL SWITCH		X	
42	WASHER CONTROL SWITCH		X	
43	4-WAY HAZARD SWITCH		X	
44	TELMA HAND CONTROL			
45				
46				
47				
48				
49	BATTERY SWITCH		X	
50	DIAGNOSTICS PANEL		X	
A	BLANK	-		
B	ABS DIAG SWITCH/IND	AMBER	X	
C	DPF REGEN SWITCH/IND	AMBER	X	
D	ENGINE DIAG SWITCH/IND (CUMMINS)	RED	X	
D	ENGINE DIAG IND (DETROIT DD13)	RED	X	
E	DPF REGEN INHIBIT SWITCH/IND	GREEN	X	
F	ENG/TRANS/ABS J1939 DIAG PORT	-		
-	-	-		
51				
52				
53				
54				
55				
56	ALARM 1		X	
57	ALARM 2			
58	DOOR OPEN ALARM - CHIME TONE			
59	CAMERA SPEAKER			
60				
61				
62				
63				
64				
65	PARK BRAKE		X	
66	INTERAXLE DIFFERENTIAL LOCK/IND	RED	X	
67	EMERGENCY SHUTDOWN			
68	TILLER JACKKNIFE WARNING LIGHT	RED		
69	VERNIER THROTTLE			
70				
71				
72				
73				
74				
75				
76	CAMERA DISPLAY		X	
77	TIRE PRESSURE MONITORING SYSTEM DISPLAY			
78				
79				
80	SEAT BELT MONITORING SYSTEM DISPLAY		X	
81	PUC SYSTEM DISPLAY PANEL			
	DIGITAL PUMP PRESSURE			
	WATER TANK LEVEL			
	FOAM LEVEL A			
	FOAM LEVEL B			
82				
83				
84				
85				
86				
87	SHIFT SELECTOR		X	
	SHIFT INDICATOR		X	
88	AIR SHIFT PUMP CONTROL		X	
	OK TO PUMP IND	GREEN	X	
	PUMP ENGAGED IND	GREEN	X	
89	PUC PUMP CONTROL			
90				
91				
92				
93				

REVISION HISTORY						
ZONE	REV	DESCRIPTION	CN	DATE	PREP	APVD
D4	A1	UPDATE ASSEMBLY	80071517	2015/05/22	P216383	P00504

Item #	Device Name	IND COLOR	STD	OPTIONAL
94				
95	DEFROSTER CONTROLS		X	
96	HEATER CONTROLS		X	
97	AIR CONDITIONING CONTROLS		X	
98	MIRROR REMOTE		X	
99	ELECTRONIC SIREN		X	
100	WINDOW DEFROST FANS			
101	VEHICLE DATA RECORDER PORT		X	
102	CUSTOMER SUPPLIED RADIO		X	
103				
104				
105				
106				
107				
108	AMMETER			
109	DUAL AMMETER			
110	PUMP HOUR METER			
111	ENGINE OIL TEMP GAUGE			
112	AIR RESTRICTION GAUGE			
113	RETARDER PSI GAUGE			
114	PUMP TRANSFER CASE TEMP GAUGE			
115	TURBO TEMP GAUGE			
116	TRANSMISSION OIL PSI GAUGE			
117	EXHAUST TEMP GAUGE			
118	OFFICER SIDE SPEEDOMETER			
119				
120				
121				
122				
123				
124	SIREN BRAKE PUSHBUTTON			
125	ELECTRONIC SIREN PUSHBUTTON			
126	AIRHORN PUSHBUTTON			
127	MECHANICAL SIREN PUSHBUTTON			
128	AIRHORN LANYARD		X	
129	DIGITAL CLOCK			
130	AM/FM RADIO		X	
131	TRAFFIC ADVISOR			
132	POWER POINT		X	
133	MINI FIVE-LT WATER TANK IND LTS		X	
134	MAP LIGHT			
135	HANDHELD SPOTLIGHT			
136	GOLIGHT CONTROL			
137	TELMA HAND CONTROL			
138	RACOR INDICATOR			
139				
140	USB PWR POINT		X	
141				
142				
143				
144				
145	RETARDER WARNING TAG			
146	TIRE CHAINS WARNING TAG		X	
147	1,2,3 BUZZER TAG			
148				
149	TRACTION CONTROL SYSTEM EQUIPPED TAG		X	
150	GENERATOR RPM TAG			
151	ROLL STABILITY CONTROL EQUIPPED TAG		X	
152	ULTRA LOW SULFUR DIESEL LABEL		X	
153				
154				
155				
156				

JOB #: 33606 SPECIAL LAYOUT BY: DVA
DATE: 05/15/19

COMMERCIAL (EAR99)
THIS DRAWING IS SUBJECT TO THE EXPORT ADMINISTRATION REGULATIONS. YOU MAY NOT PROVIDE IT TO ANY PROHIBITED END-USERS OR FOR ANY PROHIBITED END-USES AS SET FORTH IN U.S. EXPORT CONTROLS.
THIS DRAWING IS PROVIDED ON A CONFIDENTIAL BASIS SUBJECT TO RETURN ON DEMAND BY PIERCE MANUFACTURING INC. ("PIERCE"), WHICH RETAINS ANY AND ALL RIGHTS ASSOCIATED WITH IT AND THE ARTICLE OR ARTICLES IT REPRESENTS. DISCLOSURE, REPRODUCTION OR ALTERATION OF ANY PART OF THIS DRAWING, OR MANUFACTURE, USE OR SALE OF THE ARTICLE OR ARTICLES REPRESENTED, IS PROHIBITED WITHOUT THE PRIOR WRITTEN AUTHORIZATION OF PIERCE. ©PIERCE MANUFACTURING INC. (unpublished).

REFERENCE: STA	APPROVALS	USER ID	DATE	 PIERCE MANUFACTURING APPLETON, WI 54912 USA
ALL DIMENSIONS IN INCHES UNLESS OTHERWISE NOTED	PREPARED	P03609	2014/03/06	
TOLERANCE UNLESS NOTED 2 PLACES ±0.06 3 PLACES ±0.015 ANGULAR ±1.0°	APPROVED	P213372	2014/03/06	
CONTRACT NO.	MFG ENG			
	CN	-	CATIA V5R21	TITLE
	MIN: N/A			LAYOUT, INST PNL,
	FINISH: N/A			SABER
MATERIAL:	SIZE	CAGE NO.	DWG NO.	REV
	D	04664	66-0240SH2	A
	SCALE	1:1	WEIGHT	SHEET
				01 OF 01

HARDWIRE ROCKER SWITCH	IND LT ONLY	DEVICE
X		200 Emergency Master
		201 Roof Light
		202 Front Warning
		203 Side Warning
		204 Lower Rear Warning
		205 Upper Rear Warning
		206 High Beam Flash (Wig Wag)
		207 Opticom
		208 Intersector Lights
		209 Stingray
		210 Rear Warning
		211 Side Roof Lights
		212 Rear Roof Lights
		213 Front Flash
		214 Side Flash
		215 Rear Flash
		216 Front & Rear Flash
		217 Roto-Ray
		218 WIG WAG
		219 MARS LIGHTS
X		220 VISOR CUTOFF
		221 Clear Master
		222 Siren/Horn
		223 Airhorn/Elect Horn
		224 Elect/Mech Siren
X		225 Siren Brake
		226
X		227 Perimeter Lights
X		228 Drivers Scene
X		229 Pass Scene
X		230 Rear Scene
		231 Side Scene
		232 Drivers Flood
		233 Pass Flood
		234 Front Flood
		235 Rear Flood
		236 Drivers Alley
		237 Pass Alley
		238 Fog Lights
		239 Deck Lights
		240 COURTESY LIGHTS
		241 Compartment Master
		242
		243
		244 Leveling Activated
		245 Stabilizer Not Stowed
		246 Aerial PTO
		247 Aerial PTO Engaged
		248 PTO
		249 Generator PTO
		250 Generator PTO Engaged
		251 Generator Preheat
		252 Generator Start/Stop
		253 Generator Power On
		254 Generator On/Off
		255 Generator Running
		256 120V Inverter
X		257 Tire Chains
X		258 OFF-Road Traction
X		259 Fuel Primer
		260 Auto Lube Fault
X		261 REAR FOG LIGHT
		262 Mirror Heat
		263
		264
		265
X		266 Load Manager
		267 Load Manager Indicators
		268 FRONT WHEEL LOCK
		269 Blank
		270 Retarder On/Off
		271 Retarder Auto Apply
		272 Extarder On/Off
X		273 Engine Brake on/off
		274 Engine Brake Lo/High
X		275 Engine Brake Lo/Med/High
		276 DS Window
		277 PS Window
		278 DS CCab Window
		279 PS CCab Window
		280 Roto-Ray
		281 Driver/Passenger Alley
		282
		283
		284
		285
		286
		287

HARDWIRE ROCKER SWITCH	IND LT ONLY	DEVICE
		288
		289
		290 OK To Pump Ind- Stationary/Rolling
		291 Water Pump - PUC
		292 Foam System - PUC
		293 CAF System - PUC
		294 Pump And Roll - PUC
		295 TTP Valve - Open/Closed - PUC
		296
		297 Water Level
		298
		299
X		300 GE
X		301 AM FM CUTOUT
		302
		303
		304
		305 Steady Red
X		306 Differential Lock - On/Off
	X	307 Differential Lock - Activated
		308
		309
		310
		311
		312
		313
		314
		315 Rear Ground Scene
		316 DS Cab Scene
		317 PS Cab Scene
		318 DS Cab/Body Scene
		319 PS Cab/Body Scene
		320 Cab/Rear Scene
		321 Rear Work Light
		322
		323
		324
		325
		326
		327
		328
		329
		330
		331
		332
		333
		334
		335
		336
		337
		338
		339
		340
		341
		342
		343
		344
		345
		346
		347
		348
		349
		350

RED EMASER SWITCH

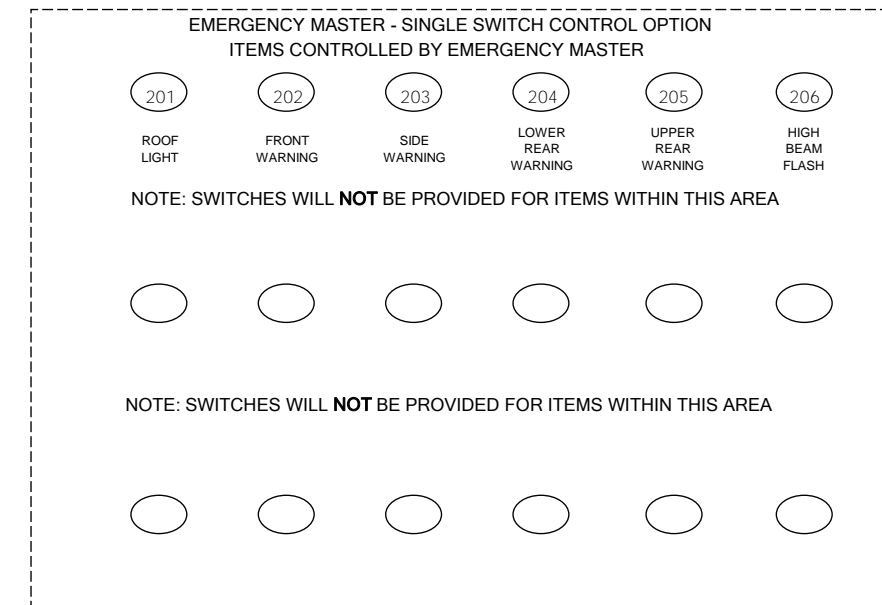
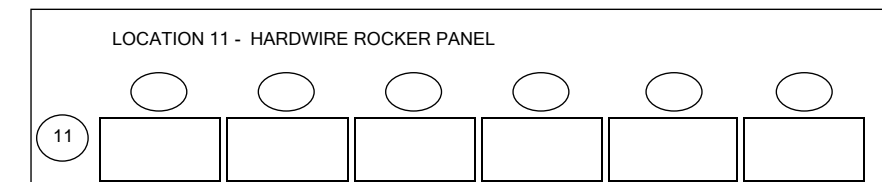
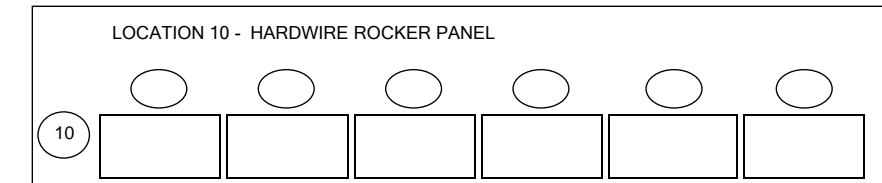
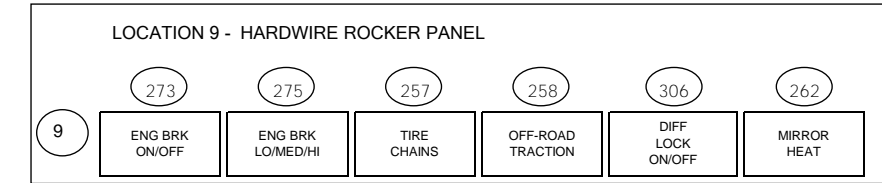
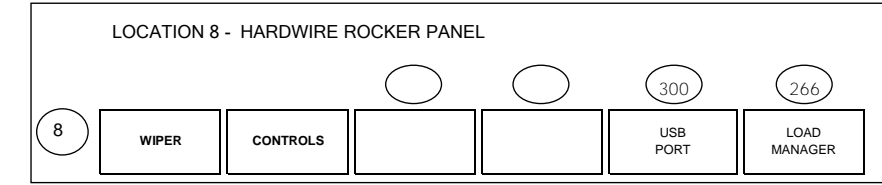
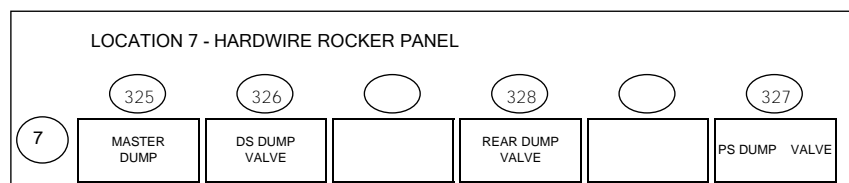
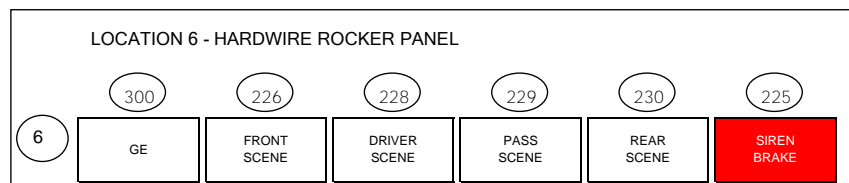
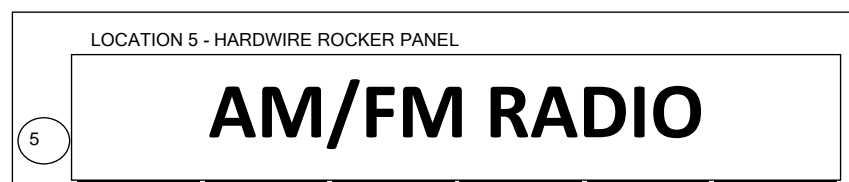
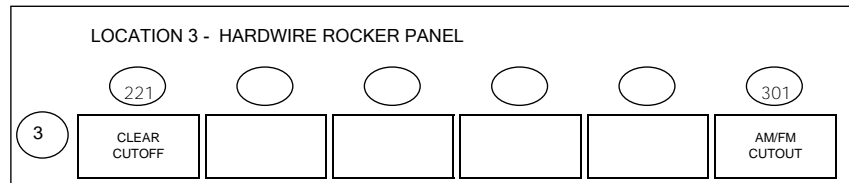
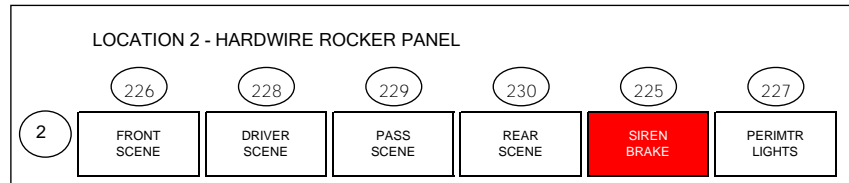
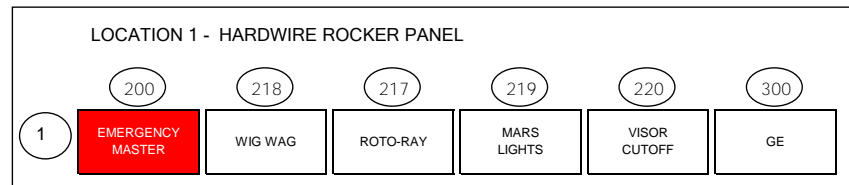

NOTES:

- FOR LOC1-LOC11, AN (X) IN A DEVICE ROW INDICATES THAT DEVICE WILL BE PROVIDED.
- BLACKED OUT AREAS INDICATE UNAVAILABLE SWITCH TYPE OR INDICATOR LIGHT FOR THE CORRESPONDING DEVICE.
- REFERENCE INSTRUMENT PANEL LAYOUT 66-0240SH1 FOR PANEL LOCATIONS.
- HARDWIRE PANELS ACCEPT ONE LABEL THAT COVERS SIX SWITCHES. EACH SWITCH POSITION CAN ACCEPT THREE LINES OF TEXT AND A MAXIMUM OF TEN CHARACTERS PER LINE.

06-19-19 ADDED "DIFF LOCK" SWITCH TO SWITCH PANEL #5.

JOB: # 33606 SPECIAL LAYOUT: _DVA_ DATE: 05/15/19

REF	SINGLE SWITCH CONTROL	FSCM NO. O4664	DATE 05MAR14	REV	DESCRIPTION	ECN	DATE	BY	CH
manufacturing inc. Appleton, Wisconsin		DRAWN RPO	05MAR14						
THIS PRINT IS LOANED ON A CONFIDENTIAL BASIS SUBJECT TO RETURN UPON DEMAND BY PIERCE MFG INC AND NOTHING HEREIN MAY BE REPRODUCED, USED OR DISCLOSED IN WHOLE OR IN PART WITHOUT THE PRIOR WRITTEN PERMISSION OF PIERCE MFG INC.		CHECKED JAN	05MAR14	TITLE	LAYOUT, INST PNL, SABER FR				
		APPROVED JAN	05MAR14	PART NO.	66-0240SH3				
				SIZE B	SHEET NO. 1 OF 1				

ATTENTION GRAPHICS DEPT:
HARDWIRE ROCKER LABEL SPECS - SEE 1425370